

Board of County Road Commissioners of the County of Kent

1500 Scribner Ave., N.W. Grand Rapids, MI 49504-3299
(616) 242-6900 Fax # (616) 242-6980

COMMERCIAL DRIVEWAYS AND PRIVATE STREET ENTRANCES ON COUNTY ROADS

1. Permit application(s) shall be in accordance with the attached GENERAL REQUIREMENTS and the following instructions.
2. The Kent County Road Commission (K.C.R.C) will advise the Applicant in the completion of the application and drive plan, but will not prepare the plan. Two copies of the drive plan must be submitted to the Kent County Road Commission Permit Department (616) 242-6920, FAX (616) 336-4397.
3. Any utility work in the right of way must be applied for on a separate application along with two copies of the utility plan submitted to Kent County Road Commission Permit Department (616) 242-6920, FAX (616) 336-4397.
4. OWNER, not Contractor must sign the application for the driveway. The original signed application must be returned; no faxes or photocopies will be accepted. Review/Permit fees (non-refundable) of \$250.00 (uncurbed) or \$300.00 (curbed) for the first driveway and \$100.00 for each additional driveway must accompany the application. Separate Review/Permit fees, and bonds for utilities will be determined by the Permit Department. Check(s) should be made out to the "KENT COUNTY ROAD COMMISSION".
5. OWNER, not Contractor must provide a surety with either a Performance Bond, Check, or Bank Letter of Credit in the amount of \$20,000 for the first driveway and \$10,000 for each additional driveway. Where road improvements are required on the existing public road in conjunction with the drive(s), the total surety amount will also include the estimated road improvement cost (plus 20% contingency). The K.C.R.C. bond form must be signed and returned with original signatures, no faxes or photocopies will be accepted. Checks will be deposited/cashed and the money will be refunded by check after final inspection approval of the completed approach by the K.C.R.C. Inspector.
6. When the above criteria has been met, the Kent County Road Commission will review the submitted plan for issuance of a permit. However, issuance of a permit does not relieve the Applicant (Owner) of responsibility for local ordinances or state laws. All work allowed by the permit must be completed within one year from date of issue. Failure to do so could result in an additional application fee, as well as the surety (Bond, Bank Letter of Credit, Check) being utilized by the Kent County Road Commission.
7. The Kent County Road Commission must inspect forms prior to placement of concrete, but will not do any staking for forms.

Questions regarding design of driveways/approaches can be directed to John Strunk at (616) – 242-6901 Ext. 6913. **Personal meetings require an appointment.**

Effective: February 1, 2010

Chairman
John W. Weiss

Vice-Chairman
David M. Groenleer

Commissioner
Patrick G. Malone

Commissioner
Mark E. Rambo

Commissioner
William N. Stellin

Jon F. Rice, P.E.
Managing Director

Steven A. Warren
Deputy Director

John L. Strauss
Director of Finance

GENERAL REQUIREMENTS
for Commercial Driveways and Private Street Entrances
on County Roads
Page 1 of 3

A. APPLICATION REQUIREMENTS

1. All applications shall be on the K.C.R.C application form, completed and signed by the Applicant (Owner). An original form must be returned; no faxes or photocopies will be accepted. No plan review will be performed without a completed application submitted.
2. All entries on the application must be printed or typewritten, except the signature. The name of the Contractor who will actually be performing the work is to be listed if known at the time of application.
3. The name of the Applicant (Owner) must be printed or typed below their signature. Address must be complete, including city, state, zip code, and owners phone number.
4. The Applicant (Owner) name/signature on the application must be the same as the Principal's name/signature on the Performance Bond Form, or Bank Letter of Credit.

B. PLAN REQUIREMENTS

1. All drawings and sketches accompanying an application are referred to as a plan, and must meet the following requirements:
 - a. Two copies (or sets) of the plan must be provided with the application unless otherwise approved. A Civil Engineer must prepare the plan, or someone with extensive experience in civil/traffic engineering road design. Plan design setup must meet K.C.R.C. requirements (see engineer for details).
 - b. A driveway approach including concrete curbed radii shall be located entirely within the area between the Applicants/Owners property/easement lines; extended to the centerline of the highway. A concrete curbed radius may extend outside of that area only if the adjacent property owner certifies in writing that he/she will permit such extension across their frontage.
 - c. It is in the interest of the Applicant (Owner) to review with the Permit Department the specific plan items required, prior to development of the plan, which will accompany the permit application. Unless waived by the reviewing agent, a plan must include the following:
 - (1) A plan view of the entire area of right of way prepared at a scale of at least 1" = 20 feet or 1" = 10 feet on sheet paper at least 24" x 36" in size.
 - (2) All right of way lines and property/easement lines pertinent to the proposed construction.
 - (3) The highway pavement width (from the centerline of pavement to the edge of the highway or white paint edge line), and shoulder widths (paved and/or gravel).
 - (4) The distance between the centerline of highway pavement and the right of way line.

GENERAL REQUIREMENTS
for Commercial Driveways and Private Street Entrances
on County Roads
Page 2 of 3

- (5) Buildings, both proposed and existing, and notation as to present use of the buildings. Details of internal traffic circulation, parking, and traffic signs may be required.
- (6) Proposed details should include widths of driveways, radii of driveway returns and other points of curvature, driveway grades, angle of the driveway relative to the road centerline, dimensions of traffic islands adjacent to the highway, driveway surface material and traffic island surface material.
- (7) From proposed drive centerline, include distance to nearest intersecting public roadway, nearest driveway(s) within 300' on adjacent properties and driveway(s) within 300' opposite the site. In addition, location of trees, curbs, sidewalks, signs, power poles, hydrants, catch basins, manholes, utilities, etc. must be shown where applicable.
- (8) Drainage information shall include existing site elevations, gutter elevations, drive culvert size, direction of water flow, proposed drainage outlets and all invert elevations, outlet pipe size and material. The Kent County Road Commission will not accept storm water run-off that does not presently drain towards the right of way. Any run-off as a result of improvements to the site will be detained through the use of on-site detention with a controlled outlet. Run-off calculations and computations for the detention pond volume shall be submitted as part of the application. Before and after contours may be required.
- (9) A north directional arrow (oriented with north pointing to the top, or to the right of the plan sheet), scale size, and an explanatory legend of any engineering symbols used.

C. FEE

1. A Review/Permit Fee is required in accordance with the current fee schedule. No plan review will be performed without a Review/Permit Fee submitted.
2. Payment by check or money order is preferred, made payable to the Kent County Road Commission.

D. BOND, CHECK, BANK LETTER OF CREDIT

1. For a Performance Bond, only the K.C.R.C. Bond Form will be accepted. The form must be made out with the Applicant (Owner) as the Principal. The original form must be returned with the signatures of Principal and Surety in original ink. A Power-of-Attorney Form from the Surety must accompany the bond.
2. A check made payable to the Kent County Road Commission may be submitted in lieu of a Performance Bond. Checks will be deposited/cashed and the money will be refunded by check after final inspection approval of the completed approach by the K.C.R.C. Inspector.
3. For a Bank Letter of Credit, only the K.C.R.C. Letter of Credit form will be accepted. Letters of Credit must be in effect for a minimum of one year and must have an automatic renewal statement unless cancelled by an authorized agent of the Kent County Road Commission.

GENERAL REQUIREMENTS
for Commercial Driveways and Private Street Entrances
on County Roads
Page 3 of 3

E. CAUTION

1. Submit applications well before you plan to start on site construction; four to six weeks may be required for processing.
2. The Permittee will be required to:
 - a. Give notice in such form as requested to the Road Commission's Utilities-Permit designated representative at least two (2) days prior to commencement of any operations covered by the permit, or as specified.
 - b. Provide all necessary staking and supervision of operations covered by the permit. Forms for concrete curb may be checked by the Road Commission's representative upon proper notice but this shall not relieve the Permittee of responsibility to insure conformance with the permit and applicable Road Commission Standards. The Applicant (Owner) is responsible for the performance and actions of the Contractor. Failure of the Contractor to comply with the permit requirements may result in the suspension or cancellation of the permit.
 - c. Perform no work except emergency work, unless authorized by the Road Commission on Saturdays, Sundays or from 3:00 PM on the day preceding a holiday until the formal starting time on the day after the following holidays: New Year's Day, Memorial Day, Independence Day, Labor Day, Thanksgiving Day, and Christmas Eve and Christmas Day.
 - d. Provide and maintain all necessary precautions to prevent injury or damage to persons and property from operations covered by the permit.
 - e. Furnish, install and maintain all necessary traffic controls and protection during construction operations in the highway right of way in accordance with the Michigan Manual of Uniform Control Devices and any supplemental specifications set forth herein.
 - f. Advise the Road Commission's Utilities-Permits Engineer or his designated representative within seven (7) days of completion of work authorized by the permit so that final inspection may be made and where appropriate, the surety bond released.
3. Failure to comply with these requirements may result in the delay of permit approval and/or rejection of the permit application.

NOTICE

ADDITIONAL HIGHWAY PERMIT APPLICATION FORMS AND PERFORMANCE BOND FORMS CAN BE OBTAINED FROM THE KENT COUNTY ROAD COMMISSIONS WEB SITE AT:

[WWW.KENTCOUNTYROADS](http://WWW.KENTCOUNTYROADS.NET). NET

ON THE LEFT SIDE OF YOUR SCREEN CLICK ON "FORMS". READ THE INFORMATIONAL INSTRUCTIONS TO VIEW AND PRINT FORMS. THEN CLICK ON HIGHWAY PERMIT APPLICATION OR PERFORMANCE BOND TO OBTAIN YOUR NEEDED FORM. MAKE SURE THE FORMS ARE SIGNED AFTER PRINTING.

FOR ADDITIONAL COMMERCIAL DRIVE INFORMATION PACKETS, ON THE LEFT SIDE OF THE SCREEN CLICK ON "POLICIES". THEN CLICK ON COMMERCIAL DRIVEWAY PERMITS ON COUNTY ROADS.

KENT COUNTY ROAD COMMISSION
APPLICATION FOR HIGHWAY PERMIT

Date _____ 20__

Road Name _____ Width of R.O.W. _____ ft.

Location of the Work _____

Telephone # _____ Fax # _____ E-mail _____

Contractor _____ Address _____

Application/Owner _____ Address _____

This application, if approved, shall authorize only the work described herein. No other work shall be performed within the highway right-of-way by the applicant or any other party (including, without limitation, the installation of additional wires or lines along or within any facilities or structures described with this application) without a separate written application approved by the Kent County Road Commission. The Kent County Road Commission shall not be responsible for any damage to wires, poles, conduits or any other facilities or structures constructed or installed within the highway right-of-way. Applicant is responsible to contact Miss Dig at 1-800-482-7171 or 811, 3 days before the start of construction, excluding Saturdays, Sundays and Holidays.

Permission is requested to do the following work within the limits of the highway right-of-way and it is hereby agreed to do this work in accordance with the "Specifications and Conditions" of the Kent County Road Commission.

**DETAILED PLANS OF THE WORK MUST ACCOMPANY THIS APPLICATION
IN THE AREA BELOW DESCRIBE THE WORK REQUESTED TO BE DONE IN THE HIGHWAY RIGHT-OF-WAY**

Work to commence _____, 20____, and to be completed _____, 20____

The undersigned further agrees that if this application is approved, they will meet all legal requirements; and that they will be responsible to the Kent County Road Commission for any damages to the highway or to the highway structures or the structures of any private company within the highway right-of-way, and that they shall, well and truly, pay all damages, fines and penalties which they shall become liable to pay, and shall save the Kent County Road Commission harmless from all suits, claims, damages and proceedings of any kind due to these permitted activities and operations within the highway right-of-way.

Signature of Applicant/Owner _____ for _____

Approved by _____ of Engineering Department Date _____

Approved by _____ of Maintenance Department Date _____

Approved by _____ of Traffic Department Date _____

**KENT COUNTY ROAD COMMISSION BOND FORM
FOR COMMERCIAL DRIVEWAYS AND PRIVATE STREET APPROACHES**

For a performance bond, only the Kent County Road Commission bond form will be accepted.

The form must be made out with the property owner as the principle.

An original blue ink signature copy must be submitted; signatures of principle and surety must be original.

Three photocopies of the blue ink signature copy must also be attached.

In addition, a power of attorney form from the surety must be attached to the submitted bond form.

BOND NO. _____

K.C.R.C. PLAN NO. _____

KENT COUNTY ROAD COMMISSION

BOND

TO ACCOMPANY APPLICATION FOR PERMIT

KNOW ALL MEN BY THESE PRESENTS,

That _____ as Principal, and

_____ as surety are held and firmly bound unto the County of Kent, and the Board of Kent County Road Commissioners or their assigns, in the penal sum of _____ Dollars, lawful money of the United States of America, for the payment of which, well and truly to be made to the said County of Kent and the Board of Kent County Road Commissioners or their assigns, we bind ourselves, our heirs, executors and administrators, jointly and severally, firmly by these presents.

Sealed with our seals and dated this _____ day of _____ A.D. 20_____.

WHEREAS, the above bounden _____ has made application to said Kent County Road Commission for a permit as stated in the application therefore.

NOW THEREFORE, The condition of this obligation is such that if the above bounden Principal shall do and perform all work done and performed under said permit in a careful, secure, skillful and workmanlike manner, and shall so guard the work authorized by the said permit, and the materials for use during the progress thereof, that no injury, loss or damage shall occur to persons or property, and shall promptly at the conclusion of such work replace and restore the street or highway and right of way to as good a state and condition as the same was previous to and at the time of opening of the same, and shall so replace and restore such street or highway and right of way as to cause it to be in a state of reasonable repair so as to be reasonably safe and convenient for public travel, and the satisfaction of the Board of Kent County Road Commissioners, and shall save the County of Kent and/or said Board of Kent County Road Commissioners harmless from all claims, suits, actions, damages, or judgments against it which shall arise out of any failure on the part of the above bounden Principal to comply with the terms of this bond, and if the said above bounden Principal shall also observe the statutes of the State of Michigan, and the ordinances of the County of Kent, shall comply with all articles set forth in the permits and shall pay all bills rendered by said Board of Kent County Road Commissioners to complete or repair in accordance with permit requirements, or replacement of pavement, roadway and right of way where disturbed or displaced by this work, then this obligation shall be null and void, otherwise to be and remain in full force and effect.

Principal _____ (Signature) _____ Principal's Address

Surety _____ (Signature) _____ Surety's Address

DO NOT WRITE BELOW THIS LINE - FOR USE OF PERMIT DEPT. ONLY

INSTRUCTIONS TO PERMIT DEPT. - White copy to be retained on file. At time permit is issued, lower left block to be filled out on all copies, and Blue copy sent to Surety. When work is satisfactorily completed, or permit is cancelled, lower right hand block to be filled out on all remaining copies, and Pink copy sent to Surety, Buff copy sent to Principal.

NOTICE TO SURETY OF PERMIT ISSUANCE

This is to inform you that a permit, covered by the above bond, has been issued as follows:

APPLICATION NO.

PERMIT NO. DATE

OWNER

CONTRACTOR

Please include this information on all correspondence concerning the bond.

NOTICE OF TERMINATION OF LIABILITY

This is to inform you that:

The permit operations covered by the above bond have been satisfactorily completed.

The permit covered by the above bond has been cancelled.

Liability under the bond is therefore terminated effective

By: _____

Title _____

ADDITIONAL REQUIREMENT FOR WORK WITHIN
COUNTY HIGHWAY RIGHT OF WAY

NOTICE

PERMIT APPLICANTS AND THEIR CONTRACTORS ARE SUBJECT TO:

PARK 91, SOIL EROSION AND SEDIMENTATION CONTROL (SESC), of the Natural Resources and Environmental Protection Act, 1994 PA 451, as Amended. A permit may be required for SESC.

Contact the KCRC Permit Department at 616-242-6920.

PRIVATE STREET ENTRANCE (EXAMPLE)
RURAL COUNTY ROAD WITH A.D.T. UNDER 1,000

FOR CULVERTS WHERE APPLICABLE, CORRUGATED METAL PIPE (MIN. 12" I.D.)
OR SMOOTH LINED CORRUGATED PLASTIC PIPE (TYPE S - MIN. 12" I.D.)
MAY BE USED. MUST MEET KCRC REQUIREMENTS.

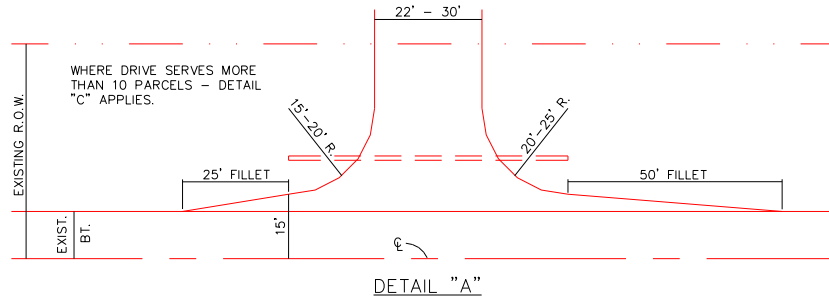

PRIVATE STREET ENTRANCE (EXAMPLE)
RURAL COUNTY ROAD WITH A.D.T. BETWEEN 1,000 - 2,000

FOR CULVERTS WHERE APPLICABLE, CORRUGATED METAL PIPE (MIN. 12" I.D.)
OR SMOOTH LINED CORRUGATED PLASTIC PIPE (TYPE S - MIN. 12" I.D.)
MAY BE USED. MUST MEET KCRC REQUIREMENTS.

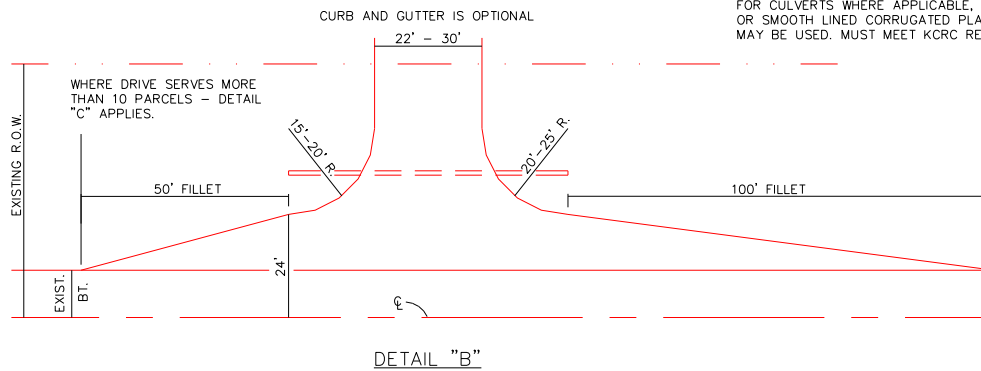

PRIVATE STREET ENTRANCE (EXAMPLE)
RURAL COUNTY ROAD WITH A.D.T. OVER 2,000
AND COMMERCIAL DRIVEWAY APPROACH

FOR CULVERTS WHERE APPLICABLE, CONCRETE PIPE IS REQUIRED
ON ALL CURBED DRIVES. (CLASS A CONC. MIN. 12" I.D.)

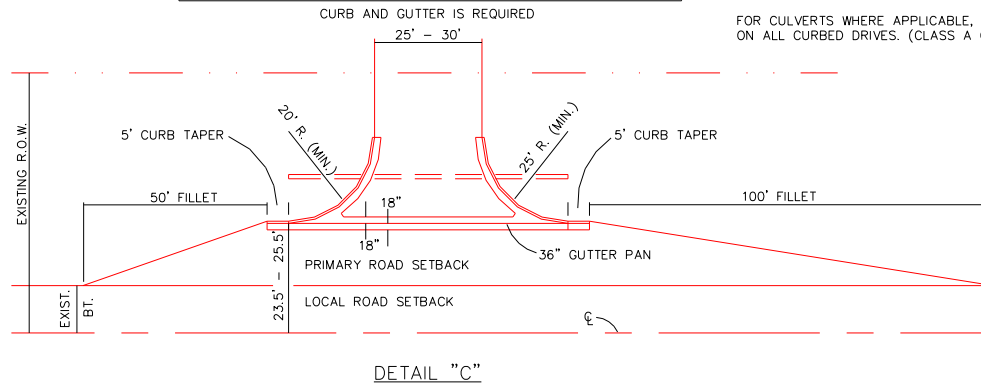

K.C.R.C. GENERAL NOTES

1. All workmanship and materials shall be according to the current Michigan Department of Transportation (M.D.O.T.) Standard Specifications for Construction.
2. Driveway approach to be bituminous or concrete. Concrete shall be used when the distance between the new curb and the highway right of way, or street edge of sidewalk, is 15 feet or less.
3. Concrete curb and gutter to be F-4 or as approved by the K.C.R.C. Engineer.
4. Where poor soil conditions exist, the depth of the gravel and sand subbase between the new curb and existing pavement, shall be determined by the Engineer.
5. No advertising sign or device shall be placed in, or overhang into the existing highway right of way.
6. Kent County Road Commission is to be notified 48 hours prior to the start of construction; excluding Saturdays, Sundays, and Holidays. This agency will inspect all work within the highway right of way. Concrete forms must be inspected by the K.C.R.C. Inspector before concrete is poured.
7. Prior to the start of construction, it will be mandatory for the applicant or contractor to have in place the necessary safety traffic signs, cones, barricades and any other safety device to insure safety to the public. No lane closures will be allowed from November 1st to April 1st unless approved by the K.C.R.C. Engineer.
8. All disturbed areas are to be leveled and restored with topsoil, seeded with an approved turf seed mix, and allowed to grow to a mowable condition so as to prevent future erosion or maintenance problems. Slopes that are 1 on 2 or steeper shall be sodded.
9. The highway right of way shall not be used for private business purposes.
10. No parking of vehicles, equipment, or material storage permitted within the highway right of way.
11. The owner must provide for adequate drainage from parking areas, and clear same with the Kent County Road Commission. Issuance of a permit does not alleviate owner of this responsibility.
12. Culverts, storm sewers, or other drainage structures shall be inspected by the Kent County Road Commission Inspector before backfill is placed.
13. Water from this property shall not drain into County or State Highway right of way without approval.
14. Resurface existing public roadway as necessary to fit drive approach, correct crown, correct drainage, or repair damage by construction. Sawcut remove all curb, concrete, and bituminous as required by the Kent County Road Commission.
15. Property owner is responsible for obtaining a Soil Erosion & Sedimentation Control Permit for any earth change greater than one acre, or within 500 feet of a regulated water of the State.
16. A utility permit must be obtained for placement and hookup of utilities (i.e. water, gas, oil, sewer, telephone, electric, cable TV, etc.) in the highway right of way.
17. Contact "Miss Dig" toll free at 1-800-482-7171 or 811 three (3) days prior to the start of construction, excluding Saturdays, Sundays, and Holidays.
18. Additional work (bituminous paving, grading, etc.) may be required by the Kent County Road Commission Inspector to correct poor workmanship and/or alleviate drainage problems.
19. All work in the highway right of way approved by a commercial drive/private street approach permit must be completed within one year of permit issuance date.
20. Performance Bonds, Letters of Credit, and Bank Cashiers Checks (in lieu of a bond) must remain in effect through one winter season to spring season after the completion of work allowed under the permit.
21. Kent County Road Commission reserves the right to terminate or revoke any permit if any terms, construction, or safety requirements as deemed necessary by the Road Commission or as shown on the approved permit plan are not met, or resolved in a timely manner.
22. Any paving performed in the highway right of way between November 1st to May 1st requires prior approval from the K.C.R.C. Engineer.

**KENT COUNTY ROAD COMMISSION
SPECIFICATIONS AND CONDITIONS
FOR HIGHWAY PERMITS**

Effective May 2, 2005

1. **Definition of Terms:** Whenever the term Road Commission is used in the following specifications it shall mean the Board of County Road Commissioners of the County of Kent. The term Engineer shall mean the County Engineer of the Road Commission or his authorized representatives. The term Contractor shall refer to the individual, firm, corporation, township, or municipality undertaking the execution of the work under the terms of the permit.
2. **Bonds and Insurance:** Surety Company Bonds in the amount of \$10,000.00 conditioned upon performance of the conditions of the permit and these specifications and compliance with all requirements of the law shall be filed with the Road Commission each year by contractors desiring to obtain highway permits through the year. Also, a certificate of insurance in the amount of \$200,000.00-\$500,000.00 public liability and \$100,000.00 property damage protecting the Kent County Road Commission against any and all claims for damages arising from operations covered by the permit shall be filed with the Road Commission each year..
3. **Additional Permits:** When the work involved is in connection with any sewer or water system, this permit is issued contingent on the contractor obtaining the necessary permit from the authorities in control of the system for making the proposed extensions and additions.
4. **Traffic Protection:** The contractor shall provide, erect, and maintain all necessary barricades, lights, and warning signs to properly safeguard traffic while this work is in progress. The contractor shall designate a foreman who shall be in responsible charge of the work. The contractor must give the foreman authority to carry out all the provisions contained in these Specifications and Conditions for Highway Permits. If the contractor fails or refuses to carry out these provisions at the time, and in a manner which in the opinion of the Engineer is necessary to protect and direct traffic, or if the contractor cannot be located and notified to do so, the Road Commission shall have the right to perform the work and the contractor shall reimburse the Road Commission for all charges incurred in the work.
5. **Interfering Structures:** In case it is necessary to move any building or structure above or below ground within the right-of-way of the highway, the same shall be replaced to the satisfaction of the Engineer. Underground structures damaged by boring shall be repaired or replaced.
6. **Construction Machinery:** All construction machinery shall be equipped with pneumatic tires when any work is done on blacktop or concrete surfaced pavements.
7. **Pavement Openings:** Structures shall be placed under pavement by boring and jacking, or cutting through the pavement and using an open trench. Tunneling will not be permitted. Cuts through concrete pavement shall be at right angles to the pavement centerline and shall be made at least six(6) inches wider on each side than the width of the trench with a minimum width of thirty-six(36) inches. Removal of all concrete pavement shall be done only with concrete saw and chisels operated by hand or compressed air. Pavement crushers of any type are prohibited. Openings shall be trimmed in straight lines with right angle corners and vertical edges. When openings are three(3) feet or less from expansion or construction joints, the pavement shall be removed to the joint.
8. **Crossing Roadbed by Boring and Jacking:** When the pipe is installed by boring and jacking, the leading edge of the pipe must precede the auger by a distance equal to one-half the diameter of the pipe. The method to be used shall be approved by the Engineer before work is started.
9. **Width of Trenches:** Open trenches shall be not less than two(2) feet wide, plus the diameter of the pipe, at the bottom of the excavation; and the maximum width shall be the diameter of the pipe, plus three(3) feet, or as stated on the permit. The slope of the excavated trench shall not be less than one to one.
10. **Cribbing:** Cribbing shall be used for all trenches where necessary to protect the road surface adjacent to the trench, for safety to the workmen, to safeguard other structures within the highway, and to prevent property damage.
11. **Excavated Material:** Excavated material shall be deposited so it will not interfere with moving traffic; and precautions must be taken to prevent excavated material from spilling out onto the travelled portion of the highway by temporary wooden retaining walls or other means approved by the Engineer.
12. **Backfill within Travelled Way:** Backfilling trenches within the travelled portion of the street or road, that is, between the shoulders or curb lines, shall be done as follows: Material shall be sand, gravel, or sandy gravel and shall be placed in successive layers not more than six(6) inches in depth, loose measure, and each layer shall be thoroughly compacted by mechanical compaction and all backfill subject to check by the Controlled Density Method showing a minimum of ninety-five percent(95%) Proctor. All material excavated from the trench, and not used in the backfill, shall be hauled away.
13. **Backfill Outside Travelled Way:** Backfilled trenches outside the travelled portion of the highway, that is, between the shoulders or curb and right-of-way lines, shall be done as follows: Material may be sand, gravel, or the material removed from the trench, if not frozen, except across driveways where the materials shall be sand, gravel, or sandy gravel. All backfill shall be placed in successive layers not more than twelve(12) inches in depth, loose measure, and each layer shall be thoroughly compacted by mechanical compaction and all backfill subject to check by the Controlled Density Method showing a minimum of ninety percent(90%) Proctor. Topsoil and sod shall be replaced in all trenches across lawns. All material excavated from the trench, and not used in backfill, shall be hauled away.
14. **Tree Roots:** When tree roots are removed because of trenching, the top of the trees shall be trimmed sufficiently to balance the loss of roots. This trimming shall be done by the contractor under the direction of the Kent County Road Commission at the contractor's expense. When tree roots are bored for underground utility installations, the distance shall be one(1) foot for each one(1) inch of trunk diameter.
15. **Temporary Crossings:** When directed by the Engineer, temporary crossing shall be provided over open trenches; and temporary wearing surface shall be placed over backfilled trenches to keep traffic moving or furnish access to abutting property.
16. **Replacing Wearing Surface:** Permanent wearing surface of bituminous material approved by the Engineer shall be placed in trenches on all blacktop surfaced roads. The thickness shall be equal to the depth of the original blacktop or three(3) inches, whichever is greater. Permanent wearing surface of seven(7) inches of road gravel approved by the Engineer shall be placed in trenches on all gravel or dirt roads. Permanent wearing surface on concrete surfaced roads shall be new concrete pavement of the same type, thickness, and quality as the original pavement. All permanent wearing surfaces shall be placed by the applicant at his own expense.
17. **Location of Facilities:** All facilities, both below ground and above ground, shall be located as directed by the Kent County Road Commission. Pipes shall be placed to a depth that will provide not less than four(4) feet of cover between top of roadway surface and the pipe. If at any time the position of the facility interferes with improvements to the highway, it shall be the responsibility of the applicant to move the facility to a location satisfactory to the Road Commission. All such moving shall be done at the expense of the applicant.
18. **Sidewalks:** New sidewalks shall be five(5) feet wide and shall be not less than four(4) inches thick. Material and construction shall comply with the requirements of the Michigan Department of Transportation current specifications for construction. Contractor shall grade off area on a straight line between finished sidewalk, and shoulder line or curb line; and any excess dirt shall be hauled away. The Engineer will furnish lines and grades for sidewalks.

19. Moving Oversize or Overweight Objects:

A. Oversize, or overweight objects:

1. Contractor shall submit an application to the Engineer for approval forty eight(48) hours in advance of the move.
2. All moving shall be done on pneumatic tired trucks, trailers, moving dollies, or a combination of them; and the load shall be distributed so that no axle will carry more than legal loading.
3. Motive power shall be by pneumatic tired truck or tractor and shall be of sufficient size to handle the load without slipping.
4. Moving will not be permitted on Saturdays, Sundays, Holidays, or the day before a Holiday.
5. Contractor shall furnish the necessary traffic protection in accordance with Kent County Road Commission requirements before a move is made in the road right-of-way.

B. Oversize and overweight objects:

1. Contractor shall submit an application to the Engineer for approval seven(7) days in advance of the move.
2. All moving shall be done on pneumatic tired trucks, trailers, moving dollies, or a combination of them.
3. Items 3, 4, and 5 above shall also apply.

20. Starting the Work: The Engineer shall be given forty eight(48) hours notice before any of the work governed by this permit is started. Street openings shall not be started on Saturdays, Sundays, Holidays, or the day before a Holiday.

21. Restoration of Highway: The contractor shall carry on his work as here-in specified; and upon completion of the work shall restore the highway to the same condition as before the work started, including sodding, seeding, and mulching.

22. Tree Planting in Road Right-of-Way: Applicant shall submit an application to the Engineer for approval of species and location of trees in the road right-of-way.

23. Copy of Permit: The Foreman in charge of this work shall have a copy of the permit and of the specifications and conditions in his possession at all times.

24. Failure to Obtain Permit: The Road Commission reserves the right to double all fees listed hereafter where a contractor performs work in the right-of-way without the proper permits.

25. Plan Approval: Allow up to two(2) weeks for water and sewer projects.

26. Fees: All fees shall be paid at the time of obtaining permit and shall be computed according to the following schedule:

A. Transportation:

Moving oversize, but not overweight objects 12 feet-6 inches wide or less	\$25.00
Moving oversize, but not overweight objects more than 12 feet-6 inches wide but less than sixteen(16) feet wide	\$25.00
Moving oversize, but not overweight objects sixteen(16) feet wide or wider (plus time and material)	\$35.00
Moving oversize and overweight objects less than 16 feet wide	\$25.00
Moving oversize and overweight objects sixteen(16) feet wide or wider (plus time and material)	\$35.00
Extended transportation	\$100.00
Annual mobile home(14 feet wide) - up to two approved routes.....	\$100.00
Annual mobile home(16 feet wide) - one approved route only.....	\$100.00
House / Structure move (plus time and material)	\$60.00

B. Establishing Grades:

Building, landscaping, and approach walks at the road right-of-way	\$120.00
Sidewalks, minimum charge for 100 lineal feet or less	\$120.00
Sidewalks, per foot charge for more than 100 lineal feet.....	\$1.20

C. Driveways:

Residential concrete driveway with sidewalk stakings.....	\$120.00
Residential concrete driveway	\$85.00
Residential concrete driveway/sidewalk restakings.....	\$85.00
Residential gravel driveway	\$50.00
Residential blacktop driveway	\$50.00
Private Street Approach (no curb and gutter)	\$250.00
Commercial driveway	\$300.00
Commercial driveway, each additional driveway.....	\$100.00

D. Underground:

Open cuts (With a fifteen (15) foot minimum trench width , one lane).....	\$250.00
(With a fifteen (15) foot minimum trench width, multiple lanes)	\$400.00
Lateral hookups(water, sewer, etc.), per lateral, not crossing road	\$30.00
Underground facilities crossing road by boring and jacking, per crossing -Residential.....	\$50.00
- Other	\$100.00
Pipeline systems for water, steam, gas, or oil, parallel to road, per lineal foot40
Sewers, storm or sanitary, parallel to road, per lineal foot.....	.50

E. Seismographic Surveys:

Annual blanket fee	\$300.00
--------------------------	----------

F. Soil Borings:

Per job minimum	\$50.00
Over 25 bores.....	\$100.00

G. Visual Inspection:

Springtime hauling.....	\$250.00
-------------------------	----------

H. Miscellaneous:

Street signs.....	\$100.00
Aerial to existing poles.	\$0.02 / line foot minimum \$100.00
All permits not listed above	\$50.00