



KENT COUNTY ROAD COMMISSION

POLICY

No.
402

Effective Date
08/28/89

Revised Date
04/01/10

Right-Of-Way Regulations For Driveways, Banners, And Parades

Policy authored by Engineering Division

The Board has established rules and procedures to regulate driveways, banners, and parades upon and over highways under the jurisdiction of the Kent County Road Commission. They have been established in accordance with 1969 Public Act 200 of the State of Michigan as amended.

KENT COUNTY ROAD COMMISSION

Rules to regulate driveways, banners and parades upon
and over public highways under the jurisdiction of the
Board of County Road Commissioners of the County of Kent.

Promulgated in accordance with Act No. 200 of the
Public Acts of 1969 of the State of Michigan

Effective date: August 28, 1989

Revised: April 1, 2010

TABLE OF CONTENTS

SECTION	TITLE	PAGE
1	GENERAL PROVISIONS	1
2	COMMERCIAL DRIVEWAYS	3
3	PRIVATE STREET ENTRANCES	6
4	RESIDENTIAL DRIVEWAYS	9
5	FIELD ENTRANCE DRIVEWAYS	11
6	BANNERS	12
7	PARADES - CELEBRATIONS - FESTIVALS	14
8	CONDITIONS OF ISSUANCE OF DRIVEWAY PERMITS	15
9	PERMIT PROCEDURE	16

SECTION 1

GENERAL PROVISIONS

A. Permits Required

Subsequent to the effective date of these rules, no person, organization, or governmental unit shall construct, reconstruct, relocate, surface, use or maintain a driveway within the public highway right-of-way unless a permit for the allowance of such activity has been obtained from the Kent County Road Commission (K.C.R.C.). In addition, no person, organization, or governmental unit shall erect a banner, decoration, or similar object to overhang the traveled portion of a public highway. Nor shall any person, organization, or governmental unit close a portion of a public highway for a parade, celebration, festival or similar activity unless a permit for the allowance of such activities has been obtained from the Kent County Road Commission.

Permits for driveways shall be granted in accordance with the provision of SECTION 2 - COMMERCIAL DRIVEWAYS, SECTION 3 - PRIVATE STREET ENTRANCES, SECTION 4 - RESIDENTIAL DRIVEWAYS, and SECTION 5 - FIELD ENTRANCE DRIVEWAYS. When the type or volume of traffic using an existing driveway changes because of a change in zoning or roadside development, the owner, organization, or governmental unit responsible for operation of the driveway may be required to obtain a permit and correct the driveway or driveways to the standards in these rules.

An authorized official designated by resolution of the governing body of a city, incorporated village, or township must request permits for banners, decorations, or similar objects to overhang the traveled portion of a public highway; and to temporarily close a portion of a public highway for a parade, celebration, or festival. Permits for banners, decorations, or similar objects over the traveled portion of a public highway shall require that they be securely fastened and are at least 18 feet above the surface of the traveled portion of the public highway.

Requests for temporary closing of public highways shall indicate the time and date the public highway is to be closed to traffic, the time and date the public highway is to be reopened for traffic, and the purpose of the public highway closure. No permit shall be issued for the temporary closing of a public highway unless approvals have been made with the K.C.R.C. to redirect the public highway traffic during such closure and implement warning devices in accordance with the Michigan Manual of Uniform Traffic Control Devices.

B. Failure to Comply

The K.C.R.C. has the right to halt any activity in the event of failure to comply with the terms and conditions of any permit issued in accordance with these rules or failure to obtain an appropriate permit. Any costs incurred by the K.C.R.C. to correct any failure to obtain a permit, comply with the conditions and standards of permits, or any defective construction will be paid by the person, organization, or governmental unit involved.

C. Clear Vision Areas

At intersections or railroad crossings where a public highway authority has purchased limited access right-of-way to provide a clear vision area, no driveway shall enter or cross any part of that clear vision area. No structures, parked vehicles, trees, or anything that obscures vision shall be placed or allowed in the clear vision area.

D. Appeal of Permit Denial or Revocation

In the event a request for a permit is denied or an existing permit is revoked and a dispute results, the settlement of the dispute shall be determined by the Board of County Road Commissioners of the County of Kent.

SECTION 2

COMMERCIAL DRIVEWAYS

A. Definition

For purposes of these rules, a commercial driveway is any driveway other than a private street entrance, residential driveway, or field entrance driveway as defined in these rules.

B. Geometric and Construction Standards (See detail on page 8)

- 1. Width:** All commercial driveways shall have a width sufficient for the particular land use and anticipated traffic flow with a minimum width of 16 feet for a one-way drive and 25 feet for a two-way drive. The maximum width shall be 19 feet for a one way drive and 36 feet for a two way drive, except 42 feet may be allowed or required to provide for an entrance lane and two exit lanes. These widths shall be measured at right angles to the centerline of the driveway at the right-of-way line.
- 2. Radii:** All commercial driveways shall have radii large enough to accommodate the largest vehicle that will normally use it without creating undue congestion or hazard in the drive or on the through public highway. The minimum entrance radius allowed shall be 25 feet and the minimum exit radius allowed shall be 20 feet, unless approved by the Traffic and Safety Engineer of the Kent County Road Commission (K.C.R.C.).
- 3. Location:** Driveways shall be located so that no undue interference with the free movement of public highway traffic will result and to provide the best vision and grade conditions. No portion of a commercial driveway shall be located closer than 45 feet from the edge of the driveway to the nearest right-of-way line of an intersecting public road. No portion of two commercial driveways serving the same property shall be located closer than 50 feet measured edge to edge. All measurements are along the right-of-way line. Unless written permission is obtained from adjacent property owners, no portion of a curbed commercial driveway radius shall extend beyond the adjacent property lines extended to the edge of the road.
- 4. Extra Lanes:** Where two driveways are less than 135 feet apart at the right-of- way line, and abut a 2-lane road, a connecting traffic lane must be constructed between driveways. A 100-foot entrance taper will be required at the near driveway on the approaching side, and a 50-foot exit taper at the far driveway.
- 5. Tapers, Deceleration Lanes, and Left Turn Lanes:** A minimum of a 100-foot entrance and a 50-foot exit taper are required. High traffic generator commercial establishments such as shopping centers, department stores, restaurants, or any development that may have great impact on the service ability of adjacent highways, may require deceleration lanes and /or left turn lanes opposite the driveway to facilitate the anticipated traffic flow. The Engineering Department of the K.C.R.C. will review the proposed driveway scheme and, if needed, will make recommendations consistent with public safety based on traffic volumes and traffic patterns.

6. **Angled Driveways:** If approved, dual commercial driveways at other than 90 degrees to the centerline of the public road shall not have less than a 45-degree angle to the centerline of the road. The near driveway on the approaching side and the far driveway shall not have less than a 60-degree angle to the centerline of the public road.
7. **Profile:** All commercial driveways shall be built to a sidewalk elevation at the right-of-way line in accordance with the Kent County Road Commission's Standard Design Guide for Driveway Grades. Beyond the right-of-way line, the grade shall not exceed 8 percent.
8. **Drainage:** The commercial driveway shall be constructed so that the drainage of or along the public roadway is not adversely affected, including the subgrade. Drainage from adjacent parking, storage, or building areas shall not be greater than what historically drained from the area. Any drainage going into the public highway right-of-way must be approved by the Engineering Department of the K.C.R.C. All drainage structures within the right-of-way, such as culvert pipe and catch basins, shall be in accordance with the Kent County Road Commission's current standard. All culvert pipes shall be no smaller than the nearest upstream culvert, nor less than 12 inches (inside diameter).
9. **Surface and Concrete Curb:** All commercial driveways shall be paved within the public right-of-way with 1.5 inches of bituminous mixture 4C over 2.0 inches bituminous mixture 3C over 8 inches of compacted aggregate (21-AA mod.) over 12 inches sand subbase (Class II) (local roads), or 18 inches of sand sub-base (Class II) (primary roads). If a concrete approach is desired, a minimum of 6" concrete over the aforementioned sand sub-bases is required. All must have K.C.R.C. F-4 concrete curb and gutter with a 5 foot tangent curbed section parallel to the road at the end of each radius tapering from a 6 inch curb head height exposure to 0 exposure. A standard 36-inch concrete gutter pan shall be provided across the drive opening. The Engineering Department of the K.C.R.C. may determine other surface material, sub-base, and curb and gutter design.

The curb shall be set back to the future pavement width. The area between the concrete curb and gutter and the edge of the existing public road shall be paved with the previously mentioned surface pavement and subbase each way from the end of the radii including required tapers. When an extra lane or taper is constructed, it might also require the K.C.R.C. F-4 curb and gutter and pavement as required above. This surface and concrete curb rule may be omitted where a driveway is requested on an existing public gravel road that is not scheduled for a paving improvement and has adequate ditches for traffic control. The concrete curb rule may also be omitted where a driveway is requested on a paved road having less than 500 vehicles average daily traffic for a minimum distance of 3 miles. Also, the concrete curb rule may be omitted upon request when a site will generate very low traffic usage. All the above exceptions to using concrete curb are allowed only in situations where the public roadway traffic will be controlled by ditch sections.

10. Inspection: The permittee shall provide all necessary staking and supervision of operations covered by the permit. The Kent County Road Commission's representative upon proper notice may check forms for concrete curb, but this shall not relieve the permittee of responsibility to insure conformance with the permit and applicable Road Commission standards. The applicant is responsible for the materials, performance and actions of the contractor. Failure of the contractor to comply with the permit requirements may result in the suspension or cancellation of the permit.

C. Setback and Use of Right of Way

1. It is recommended that the property owner set back any building at least 40 feet from the public right-of-way line. Gasoline pump islands should be at least 15 feet from the right-of-way line. Local ordinances shall apply if they are more restrictive. No structures or signs will be allowed in the public right-of-way. The use of the right-of-way for commercial purposes will not be permitted. Concrete curb or equivalent roadside control that is placed across the frontage shall be no closer to the public roadway edge than the right-of-way line.

D. Joint Driveways

1. When both commercial property owners abutting a common property line agree, they may construct a joint commercial driveway, which shall meet these rules as if their frontages were under a single ownership.

E. Utility Structure Driveways

1. Low usage service driveways to private and public utility structures will be of a design approved by the Engineering Department of the Kent County Road Commission.

SECTION 3

PRIVATE STREET ENTRANCES

A. Definition

For purposes of these rules, a private street entrance is any driveway serving two or more residential parcels.

B. Geometric and Construction Standards (See details on page 8)

- 1. Width:** The minimum width allowed is 22 feet. The maximum width allowed is 30 feet. The Engineering Department of the Kent County Road Commission (K.C.R.C.) may determine dimensions other than standard.
- 2. Radii:** The minimum entrance radius allowed is 20 feet. The minimum exit radius allowed is 15 feet. These dimensions are for uncurbed entrances. The Engineering Department of the K.C.R.C. may determine dimensions other than standard.
- 3. Location:** Private street approaches shall be located so that no undue interference with free movement of highway traffic will result and to provide the best vision and grade conditions. No portion of a private street entrance shall be located closer than 45 feet from the edge of driveway to the nearest public right-of-way line of an intersecting public road. Unless written permission is obtained from adjacent property owners, no portion of a curbed radius shall extend beyond the adjacent property lines extended to the edge of the road.
- 4. Drainage:** The private street entrance shall be constructed so that the drainage of or along the public roadway is not adversely affected, including the sub-grade. Drainage from the property shall not be greater than what historically drained from the area. Any drainage going into the public highway right-of-way must be approved by the Engineering Department of the Kent County Road Commission. All drainage structures within the right-of-way, such as culvert pipe and catch basins, shall be in accordance with the Kent County Road Commission's current standards. All culvert pipes shall be no smaller than the nearest upstream culvert, nor less than 12 inches (inside diameter).
- 5. Surface and Concrete Curb:** All private street entrances shall be paved within the public right-of-way with 1.5 inches of bituminous mixture 4C over 2.0 inches bituminous mixture 3C over 8 inches of compacted aggregate (21-AA mod.) over 12 inches sand subbase (Class II) (local roads), 18 inches sand subbase (Class II) (primary roads). If a concrete approach is desired, a minimum of 6" concrete with the aforementioned sand sub-bases is required. Pavement is not required where a driveway entrance is off an existing public gravel road. Curb and gutter, where required, must be K.C.R.C. F-4 concrete curb and gutter with a 5 foot tangent curbed section parallel to the road at the end of each radius tapering from a 6 inch curb head height exposure to 0 exposure. A 36-inch concrete gutter pan shall be provided across the drive opening. The Engineering Department of the K.C.R.C. may determine other surface material, subbase, and curb and gutter design.

C. Traffic and Safety

- 1.** All private street entrances shall be located where there is sufficient unrestricted sight distance to insure safety for the motoring public. The Kent County Traffic and Safety Engineer will assist the applicant or developer in making this determination, where the situation is in question. The K.C.R.C. may require a standard “STOP” sign at the proper location where the private street entrance intersects the public road. This is the responsibility of the applicant and shall be maintained by the applicant.
- 2.** The Engineering Department of the K.C.R.C. will approve all private street names. All property owners serviced by the private street must agree upon the street name, and proper addressing. Addresses for any named private streets in the townships will be issued by the Permit Department of the Kent County Road Commission, and will be of proper address sequence for the area and direction of the private street. Street names chosen cannot be one currently used or be similar sounding to any current public or private streets in Kent County.
- 3.** After all the entrance construction work has been completed to the satisfaction of the K.C.R.C., the applicant may request that a private street sign be installed where the private street intersects to the public road. Cost of the sign and installation shall be paid in advance by the applicant. Signs made by the K.C.R.C. are limited to a total of seventeen (17) letters and spaces combined.
- 4.** Parcels on the private street will be addressed from the private street, if such is named. If the private street is not named, addresses for parcels will be from the public road.

PRIVATE STREET ENTRANCE (EXAMPLE) RURAL COUNTY ROAD
WITH A.D.T. UNDER 1,000

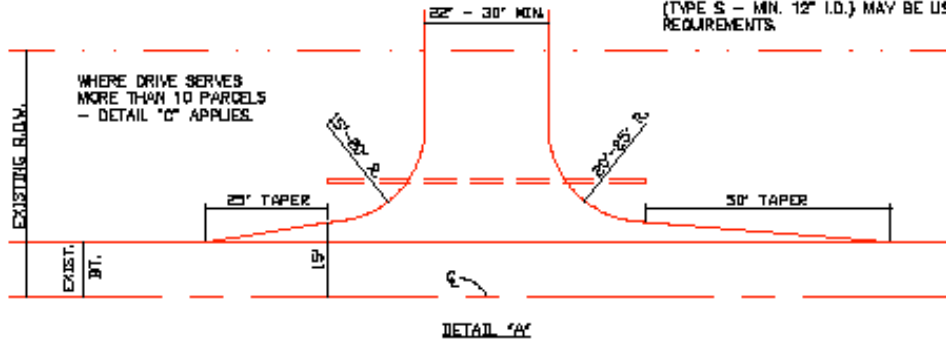

FOR CULVERTS WHERE APPLICABLE, CORRUGATED METAL PIPE (MIN. 12" I.D.) OR SMOOTH LINED CORRUGATED PLASTIC PIPE (TYPE S - MIN. 12" I.D.) MAY BE USED. MUST MEET KCRS REQUIREMENTS.

PRIVATE STREET ENTRANCE (EXAMPLE) RURAL COUNTY ROAD
WITH A.D.T. BETWEEN 1,000 - 2,000

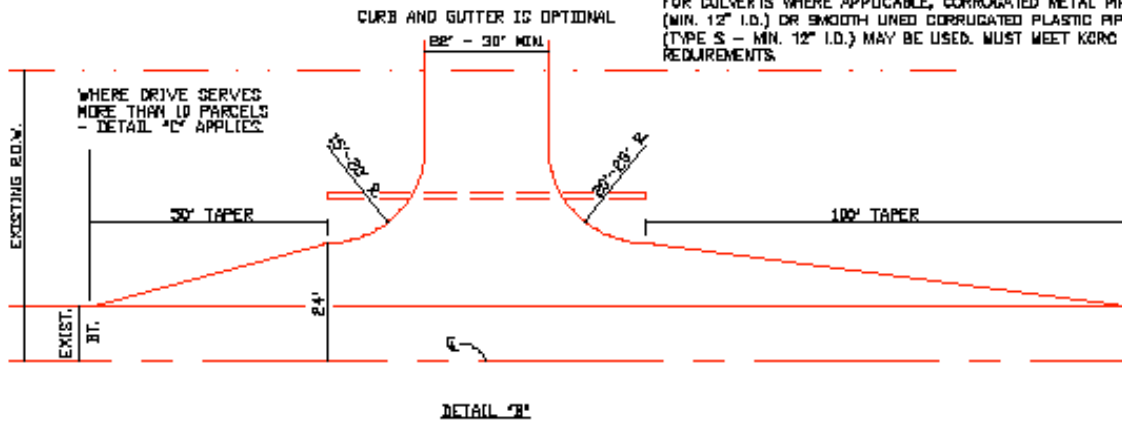

FOR CULVERTS WHERE APPLICABLE, CORRUGATED METAL PIPE (MIN. 12" I.D.) OR SMOOTH LINED CORRUGATED PLASTIC PIPE (TYPE S - MIN. 12" I.D.) MAY BE USED. MUST MEET KCRS REQUIREMENTS.

PRIVATE STREET ENTRANCE (EXAMPLE) RURAL COUNTY ROAD
WITH A.D.T. OVER 2,000 AND COMMERCIAL DRIVEWAY
APPROACH

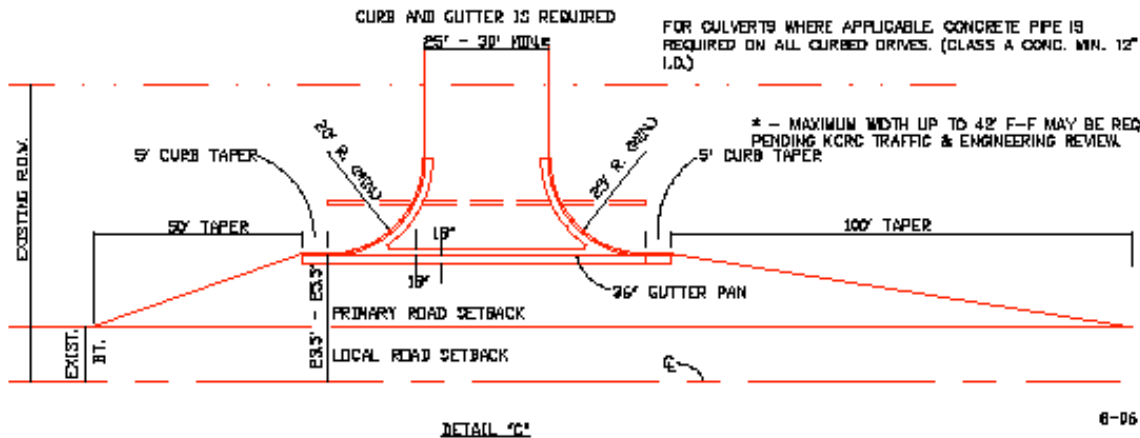

FOR CULVERTS WHERE APPLICABLE CONCRETE PIPE IS REQUIRED ON ALL CURBED DRIVES. (CLASS A CONC. MIN. 12" I.D.)

* - MAXIMUM WIDTH UP TO 42' F-F MAY BE REQUIRED PENDING KCRS TRAFFIC & ENGINEERING REVIEW

SECTION 4

RESIDENTIAL DRIVEWAYS

A. Definition

For purposes of these rules, a residential driveway is any driveway serving a single residential or two family dwelling (duplex).

B. Geometric and Construction Standards

- 1. Width:** All residential driveways shall have a minimum width of 10 feet and a maximum width of 20 feet, measured at right angles to the centerline of the driveway at the public right-of-way line.
- 2. Offset:** To facilitate vehicle movements, the driveway approach shall be offset from the entrance side of the driveway 8 feet and from the exit side of the driveway 4 feet; measured at the pavement edge unless otherwise approved by the Kent County Road Commission (K.C.R.C.).
- 3. Location:** Driveways shall be located so that no undue interference with the free movement of public highway traffic will result, and to provide the best vision and grade conditions. No portion of a residential driveway shall be located closer than 35 feet from the edge of the driveway to the nearest public right-of-way line of an intersecting public road. No portion of two residential driveways serving the same property shall be located closer than 40 feet to each other measured edge to edge. All measurements are along the public right-of-way line. Unless written permission is obtained from adjacent property owners, no portion of a residential driveway shall extend beyond the adjacent property lines extended to the edge of the road.
- 4. Number of Driveways:** One residential driveway will be permitted for each platted lot or for the first 75 feet or less of residential property in unplatted areas. Circle drives may be permitted if the frontage exceeds 75 feet.
- 5. Profile:** All residential driveways shall be built to a sidewalk elevation at the right-of-way line in accordance with the Kent County Road Commission's Standard Design Guide for Driveway Grades.
- 6. Drainage:** The residential driveway shall be so constructed that the drainage of or along the public roadway is not adversely affected. When required, culverts of a size determined by the Kent County Road Commission will be placed in accordance with the Kent County Road Commission's Driveway Culvert Policy.
- 7. Surface:** All residential driveways shall be surfaced within the public right-of-way with a minimum of 8" gravel, or a minimum of 2.0" bituminous mixture over a minimum of 6" compacted aggregate (21-AA mod.) over 12" sand sub-base (Class II), or a minimum of 6" concrete over the aforementioned sand sub-base.

8. Construction Staking: Stakes for location and elevation necessary for construction will be placed by the K.C.R.C. upon request, after issuance of the residential driveway permit.

C. Joint Driveways

1. Joint residential driveways will not be permitted.

SECTION 5

FIELD ENTRANCE DRIVEWAYS

A. Definition

For purposes of these rules, any driveway serving cultivated fields, timberland, or undeveloped land not used for industrial, commercial, or residential purposes shall be considered field entrance driveways.

B. Standards

1. The requirements for field entrance driveways shall be the same as residential driveways, except the surface shall be seeded, sodded, or better type of material. Also, the width of a field entrance may be enlarged to 30-foot maximum to accommodate large farm machinery.

SECTION 6

BANNERS

A. Definition

For purposes of these rules, a banner is an arrangement of lettering, words, symbols or a decorative device, including a Christmas decoration, suspended over any portion of a public highway or within the highway right of way.

B. Permittees

A permit for the installation of banners to be placed within a public highway right of way may be issued by the Kent County Road Commission (K.C.R.C.) only to the governing body of a city, village or township.

C. Design and Placement

1. The design, method of installation and location of banners shall not endanger persons using the public highway, public highway right of way, or unduly interfere with the free movement of traffic.
2. An overhead banner shall have a minimum bottom height of 18 feet above any pavement or ground, shall not be placed closer than 10 feet to any side of traffic signals or regulatory signs, and shall not be placed so as to obstruct a clear view of traffic signals or other traffic control devices. Banners shall not be mounted from or attached to any public agency regulatory traffic signs or signals.

D. Content of Banners

1. A banner shall not display any legend or symbol which may be construed to advertise, promote the sale of, or publicize any merchandise or commodity, or to be political in nature.
2. A banner shall not display any legend or symbol which is or purports to be an imitation of or resembles, or which may be mistaken for, a traffic control device, or which attempts to direct the movement of traffic.
3. Decorations shall not include flashing lights that may be distracting to motorists.

E. Duties of Local Governments

1. A city, village, or township receiving a permit shall faithfully fulfill permit requirements and shall indemnify and save harmless the K.C.R.C. from claims of every kind arising out of the use of an issued permit.

F. Application

1. An application for a permit for the installation of a banner shall be in the manner prescribed on the appropriate form available at the Permit Offices of the K.C.R.C.
2. An application shall include the following information:
 - a. Activity in connection with which the banners are to be placed.
 - b. Location of the proposed installation including distance to overhead traffic control devices.
 - c. Description of the banners, including language content, any legend or symbol thereon.
 - d. Height of an overhead banner at its lowest point above the pavement or ground.
 - e. Date on which the banner will be installed and removed. This period shall not exceed a time period specified by the K.C.R.C. An acceptable period of time for banners, other than Christmas decorations, to be in place is three (3) weeks, and an acceptable duration for Christmas decorations to be in place is six (6) weeks.
 - f. Such other information as the K.C.R.C. may require.

G. Resolutions

1. An application shall be accompanied by a copy of a resolution from the local governing body designating an authorized official of the city, village, or township who has authority to make applications.

H. Cancellation

1. A permit for the installation of a banner may be canceled by the K.C.R.C. if the installation is determined by the K.C.R.C. to be dangerous to motorists or unduly interferes with the free movement of traffic.

SECTION 7

PARADES – CELEBRATIONS – FESTIVALS

A. Permittees

A permit granting permission for the temporary closure of a public highway for a reasonable length of time for a parade, celebration, or festival may be issued by the Kent County Road Commission (K.C.R.C.) only to the governing body of a city, village, or township.

B. Application

1. An application for a permit to close or partially close a public highway for a parade, celebration, or festival shall be in the manner prescribed on the appropriate form available at the Permit Offices of the K.C.R.C.
2. An application shall state the nature of the activity for which the permit is requested, the dates and times it is proposed to close and reopen the public highway to traffic and such other information as the K.C.R.C. may require. The reasonable period of time shall be approved by the K.C.R.C. The application must be accompanied by a copy of a resolution from the city, village, or township requesting permission for the closure or partial closure.

C. Permit Conditions

1. The closure or partial closure and the use of a detour route shall not unduly interfere with the safe and free movement of traffic.
2. A suitable alternate location is not available for the parade, celebration, or festival, which is more acceptable for traffic safety, and causes less interruption of traffic.
3. A closure or partial closure normally shall be allowed during daylight hours only. If a temporary night time closure is permitted, points of potential hazard, barricades and traffic signs shall be lighted at the permittee's expense. The lighting shall be in accordance with requirements and specifications of the K.C.R.C.
4. The K.C.R.C. shall determine the acceptable detour routes. All traffic control devices installed in conjunction with the closure or partial closure and the detour route shall conform to the provisions of the current Manual of Uniform Traffic Control Devices.
5. Required traffic control devices shall be furnished, installed, and maintained by the local governing body the permit is issued to.
6. The local governing body shall provide necessary police supervision, and assume liability for damage claims, which may arise as a result of the closure or partial closure.
7. The closure or partial closure shall not be for the purpose of allowing private commercial activities, such as advertising or sale of goods, wares or produce.

SECTION 8

CONDITIONS OF ISSUANCE OF DRIVEWAY PERMITS

A. Conditions

All driveway permits issued in accordance with these rules shall be subject to the following conditions:

1. The property owner or lessee shall maintain all driveways set forth in the permit.
2. The Kent County Road Commission (K.C.R.C.) shall be notified at least 48 hours (excluding weekends and holidays) prior to commencement of any operation covered by the permit.
3. The owner, or his authorized agent, shall provide and maintain all necessary precautions to prevent injury or damage to persons and property from operations covered by the permit and shall use warning devices in accordance with the Michigan Manual of Uniform Traffic Control Devices.
4. All unsuitable or surplus materials shall be removed and disposed of outside of the highway right-of-way unless otherwise authorized. Excavated material and materials or equipment necessary for construction of the driveway shall be so located that the safety of traffic will not be interfered with.
5. Certificate of insurance to insure that claims for damage or personal injury can be met shall be provided in the amount currently specified by the Kent County Road Commission. Surety Bond to protect the K.C.R.C. against the cost of completing construction or correcting deficiencies shall be provided on forms obtainable from the Kent County Road Commission.
6. Driveway construction must be completed within one year from date of permit issuance. Failure to comply will result in the K.C.R.C. exercising the Surety Bond and completing the necessary construction.
7. Kent County Road Commission reserves the right to terminate or revoke any permit if any terms, construction, or safety requirements as deemed necessary by the Road Commission or as shown on the approved permit plan are not met or resolved in a timely manner.

SECTION 9

PERMIT PROCEDURE

The following procedure is required to obtain a permit for a driveway, banner, or parade within the highway right-of-way under the jurisdiction of the Board of County Road Commissioners of the County of Kent is needed:

A. Procedure:

1. The property owner or governmental agency will make an application on the appropriate form available at the Permit Offices of the Kent County Road Commission (K.C.R.C.). The application shall be accompanied by a scaled plan containing information that clearly indicates all existing and proposed items in accordance with these rules.
2. The Permit Department of the K.C.R.C. shall determine compliance of the application request to these rules and will advise on any revisions that may be necessary in order to comply.
3. The appropriate permit fees and performance bonds if applicable are submitted.
4. After review and approval, the permit is mailed or given to the property owner or governmental agency. Any details pertaining to specific requirements will be outlined on the permit and/or plan.
5. Necessary construction staking for sidewalk grades on residential driveways will be done within a reasonable time after a request is made to the Kent County Road Commission.
6. Materials, equipment, and warning devices necessary to do the work shall be obtained and the Engineering Department of the K.C.R.C. notified 48 hours (excluding weekends and holidays) before start of work.
7. All work or operations shall then be completed in accordance with all rules and supplemental conditions as outlined on the permit. Work done without prior notification or inspection by the K.C.R.C. may be required to be removed and replaced.