



## KENT COUNTY ROAD COMMISSION

### POLICY

No.  
402

Effective Date  
08/28/89

Revised Date  
02/13/18

## Right-Of-Way Regulations For Driveways, Banners, And Parades

Policy authored by Engineering Division

The Board has established rules and procedures to regulate driveways, banners, and parades upon and over highways under the jurisdiction of the Kent County Road Commission. They have been established in accordance with 1969 Public Act 200 of the State of Michigan as amended.

**KENT COUNTY ROAD COMMISSION**

Rules to regulate driveways, banners and parades upon  
and over public highways under the jurisdiction of the  
Board of County Road Commissioners of the County of Kent.

Promulgated in accordance with Act No. 200 of the  
Public Acts of 1969 of the State of Michigan

Effective date: August 28, 1989

Revised: February 13, 2018

## TABLE OF CONTENTS

SECTION	TITLE	PAGE
1	GENERAL PROVISIONS	1
2	COMMERCIAL DRIVEWAYS	3
3	PRIVATE STREET ENTRANCES	6
4	RESIDENTIAL DRIVEWAYS	11
5	FIELD ENTRANCE DRIVEWAYS	13
6	BANNERS	14
7	PARADES - CELEBRATIONS - FESTIVALS	16
8	CONDITIONS OF ISSUANCE OF DRIVEWAY PERMITS	18
9	PERMIT PROCEDURE	19

## SECTION 1

### GENERAL PROVISIONS

#### A. Permits Required

Subsequent to the effective date of these rules, no person, organization, or governmental unit shall construct, reconstruct, relocate, surface, use or maintain a driveway within the public highway right-of-way, under the jurisdiction of the Kent County Road Commission (KCRC) unless a permit for the allowance of such activity has been obtained from the KCRC. In addition, no person, organization, or governmental unit shall erect a banner, decoration, or similar object to overhang the traveled portion of a public highway, nor shall any person, organization, or governmental unit close a portion of a public highway for a parade, celebration, festival or similar activity unless a permit for the allowance of such activities has been obtained from the Kent County Road Commission.

Permits for driveways shall be in the property owners name and granted in accordance with the provision of SECTION 2 - COMMERCIAL DRIVEWAYS, SECTION 3 - PRIVATE STREET ENTRANCES, SECTION 4 - RESIDENTIAL DRIVEWAYS, and SECTION 5 - FIELD ENTRANCE DRIVEWAYS. When the type or volume of traffic using an existing driveway changes because of a change in zoning or roadside development, the owner, organization, or governmental unit responsible for operation of the driveway may be required to obtain a permit and correct the driveway or driveways to the standards in these rules.

An authorized official designated by resolution of the governing body of a city, incorporated village, or township must request permits for banners, decorations, or similar objects to overhang the traveled portion of a public highway; and to temporarily close a portion of a public highway for a parade, celebration, or festival. Permits for banners, decorations, or similar objects over the traveled portion of a public highway shall require that they be securely fastened and are at least 18 feet above the surface of the traveled portion of the public highway.

Requests for temporary closing of public highways shall indicate the time and date the public highway is to be closed to traffic, the time and date the public highway is to be reopened for traffic, and the purpose of the public highway closure. No permit shall be issued for the temporary closing of a public highway unless approvals have been made with the KCRC to redirect the public highway traffic during such closure and implement warning devices in accordance with the Michigan Manual of Uniform Traffic Control Devices.

#### B. Failure to Comply

The KCRC has the right to halt any activity in the event of failure to comply with the terms and conditions of any permit issued in accordance with these rules or failure to obtain an appropriate permit. Any costs incurred by the KCRC to correct any failure to obtain a permit, comply with the conditions and standards of permits, or any defective construction will be paid by the person, organization, or governmental unit involved.

**C. Clear Vision Areas**

At intersections or railroad crossings where a public highway authority has purchased limited access right-of-way to provide a clear vision area, no driveway shall enter or cross any part of that clear vision area. No structures, parked vehicles, trees, or anything that obscures vision shall be placed or allowed in the clear vision area.

**D. Appeal of Permit Denial or Revocation**

In the event a request for a permit is denied or an existing permit is revoked and a dispute results, the settlement of the dispute shall be determined by the Board of County Road Commissioners of the County of Kent.

## SECTION 2

### COMMERCIAL DRIVEWAYS

#### A. Definition

For purposes of these rules, a commercial driveway is any driveway other than a private street entrance, residential driveway, or field entrance driveway as defined in these rules.

#### B. Geometric and Construction Standards (See detail on page 8)

1. **Width:** All commercial driveways shall have a width sufficient for the particular land use and anticipated traffic flow with a minimum width of 16 feet for a one-way drive and 25 feet for a two-way drive. The maximum width shall be 25 feet for a one way drive and 42 feet for a two way drive or a width as determined by the Kent County Road Commission (KCRC). These widths shall be measured at right angles to the centerline of the driveway at the right-of-way line.
2. **Radii:** All commercial driveways shall have radii large enough to accommodate the largest vehicle that will normally use it without creating undue congestion or hazard in the drive or on the through public highway. The minimum entrance radius allowed shall be 20 feet and the minimum exit radius allowed shall be 20 feet, or as determined by the KCRC.
3. **Location:** Driveways shall be located so that no undue interference with the free movement of public highway traffic will result and to provide the best vision and grade conditions. No portion of a commercial driveway shall be located closer than 50 feet from the edge of the driveway to the nearest right-of-way line or vision corner of an intersecting public road. No portion of two commercial driveways serving the same property shall be located closer than 50 feet measured edge to edge. All measurements are along the right-of-way line. Unless written permission is obtained from adjacent property owners, no portion of a curbed commercial driveway radius shall extend beyond the adjacent property lines extended to the edge of the road.
4. **Extra Lanes:** When two adjacent driveways are less than 150 feet apart at the right of way line, or when two adjacent tapers (entrance and exit) touch/overlap and abut a 2-lane road, a connecting traffic lane must be constructed between driveways. A 100-foot entrance taper (min.) will be required at the near driveway on the approaching side, and a 50-foot exit taper (min.) at the far driveway. Concrete curb and gutter may be required between drives.
5. **Tapers, Right Turn Lanes, and Left Turn Lanes:** On an uncurbed roadway, a minimum of a 100-foot entrance and a 50-foot exit taper are required. High traffic generator commercial establishments such as shopping centers, department stores, restaurants, or any development that may have great impact on the service ability of the public highway, may require right turn lanes and/or left turn lanes in the public highway to facilitate the anticipated traffic flow. The KCRC will review the proposed driveway scheme and, if needed, will require recommendations consistent with public safety based on traffic volumes/counts, traffic patterns, and road conditions.

6. **Angled Driveways:** If approved, dual commercial driveways at other than 90 degrees to the centerline of the public road shall not have less than a 45-degree angle to the centerline of the road. The near driveway on the approaching side and the far driveway shall not have less than a 60-degree angle to the centerline of the public road.
7. **Profile:** Unless otherwise determined by the KCRC, commercial driveways shall be built to a sidewalk elevation at the right-of-way line in accordance with the Kent County Road Commission's Table for Determining Sidewalk Grades. It is recommended beyond the right-of-way line the grade should not exceed 8 percent, or meet local government agency requirements.
8. **Drainage:** If deemed necessary by the KCRC, site drainage plans and computations must be provided. Commercial driveways shall be constructed so that the drainage of or along the public roadway is not adversely affected, including the subgrade. Drainage from adjacent parking, storage, or building areas shall not drain into the public highway right of way or existing storm system at a greater rate than what historically drained from pre-development condition. Any drainage going into the highway right-of-way must be approved by the Engineering Department of the KCRC. All drainage structures within the right-of-way, such as culvert pipe and catch basins, shall be in accordance with the Kent County Road Commission's current standard. All culvert pipes shall be of no smaller diameter than the nearest upstream culvert, nor less than 12 inches (inside diameter).
9. **Surface and Concrete Curb:** All commercial driveways and tapers shall be paved within the public highway right-of-way with 1.5 inches of bituminous mix 5E1 over 2.0 inches of bituminous mix 3C (or thicknesses as determined by the KCRC) over 8 inches of compacted aggregate (21-AA) over 12 inches Class II sand subbase on local roads, or 18 inches of Class II sand subbase on primary roads. If a concrete approach is desired between the curbed area, a minimum of 6" concrete (MDOT S-2 spec.) over the aforementioned sand sub-bases is required. When a concrete sidewalk section is required by the local government agency to be defined through the approach, the approach must be concrete when the distance from the street side edge of side walk and back edge of concrete gutter pan is 15 feet or less. All must have KCRC B-2 concrete curb and gutter with a 5 foot tangent tapered curb section parallel to the road at the end of each radius tapering from the normal curb head height exposure to zero exposure. A standard 36-inch concrete gutter pan shall be provided across the drive opening. The KCRC may determine other surface material, sub-base, and curb and gutter design.

The curb shall be set back to the future pavement (primary/local) road width. The area between the concrete curb and gutter and the edge of the existing public road shall be paved with the previously mentioned bituminous pavement and subbase each way from the end of the radii including required tapers. When an extra lane/taper is constructed, it might also require the KCRC B-2 curb and gutter with pavement as required above. This surface and concrete curb rule may be omitted where a driveway is requested on an existing public gravel road that is not scheduled for a paving improvement and has adequate ditches for traffic control. The concrete curb rule may also be omitted where a driveway is requested on a paved road having less than 500 vehicles average daily traffic for a minimum distance of 3 miles. Also, the concrete curb rule may be omitted upon request when a site will generate very low traffic usage (as determined by the KCRC). All the above exceptions to using concrete curb are allowed only in situations where the public roadway traffic will be controlled by ditch sections.

**10. Inspection:** The permittee shall provide all necessary staking and supervision of operations covered by the permit. The Kent County Road Commission's representative upon proper notice may check forms for concrete curb, but this shall not relieve the permittee of responsibility to insure conformance with the permit and applicable Road Commission standards. The permittee is responsible for the materials, performance and actions of the contractor. Failure of the contractor to comply with the permit requirements may result in the suspension or cancellation of the permit, and possible removal and corrected replacement of curb and/or pavement at permittees expense.

**C. Setback and Use of Right of Way**

1. It is recommended that the property owner set back any building at least 40 feet from the public right-of-way line. Gasoline pump islands should be at least 25 feet from the right-of-way line. Local ordinances shall apply if they are more restrictive. No structures or signs will be allowed in the public right-of-way. The use of the right-of-way for commercial purposes will not be permitted. Concrete curb or equivalent roadside control that is placed across the frontage shall be no closer to the public roadway edge than the right-of-way line.

**D. Joint Driveways**

1. When both commercial property owners abutting a common property line agree, they may construct a joint commercial driveway, which shall meet these rules as if their frontages were under a single ownership. Joint easement agreements for the single drive must be enacted and recorded with verification given to the KCRC and local government agency.

**E. Utility Structure Driveways**

1. Low usage service driveways to private and public utility structures will be of a design approved by the Engineering Department of the KCRC.



## SECTION 3

### PRIVATE STREET ENTRANCES

#### A. Definition

For purposes of these rules, a private street entrance is any driveway with roadway serving two or more residential parcels or industrial/commercial parcels.

#### B. Geometric and Construction Standards (See details on page 8)

- 1. Width:** The minimum width allowed is 25 feet. The maximum width allowed is 30 feet. The Engineering Department of the Kent County Road Commission (KCRC) may determine and approve dimensions other than standard.
- 2. Radii:** The minimum entrance radius allowed is 20 feet. The minimum exit radius allowed is 20 feet. These dimensions are for uncurbed entrances. The Engineering Department of the KCRC may determine dimensions other than standard.
- 3. Location:** Private street approaches shall be located so that no undue interference with free movement of highway traffic will result and to provide the best vision and grade conditions. No portion of a private street entrance shall be located closer than 50 feet from the edge of driveway to the nearest public right-of-way line or vision corner of an intersecting public road. All measurements are along the right of way line. Unless written permission is obtained from adjacent property owners, no portion of a curbed radius shall extend beyond the adjacent property lines extended to the edge of the road.
- 4. Tapers, Right Turn Lanes, and Left Turn Lanes:** Entrance and exit tapers are required per the KCRC. Geometric Private Street Entrance Design (see details on pages 8 - 10). High traffic generator developments that may have great impact on the service ability of the public highway may require right turn lanes and/or left turn lanes in the public highway to facilitate the anticipated traffic flow.
- 5. Profile:** Unless otherwise determined by the KCRC, all private street approaches shall be built to a sidewalk elevation at the right of way line in accordance with the Kent County Road Commission's Table for Determining Sidewalk Grades. It is recommended beyond the right of way line the grade should not exceed 8 percent, or meet local government agency requirements.
- 6. Drainage:** Site drainage plans must be submitted. The private street entrance shall be constructed so that the drainage of or along the public roadway is not adversely affected, including the sub-grade. Drainage from the property shall not be greater than what historically drained from the land/lot area. Any drainage going into the highway right of way must be approved by the Engineering Department of the KCRC. All drainage structures within the highway right of way, such as culvert pipe and catch basins, shall be in accordance with the Kent County Road Commission's current standards. All culvert pipes shall be no smaller than the nearest upstream culvert, nor less than 12 inches (inside diameter).

7. **Surface and Concrete Curb:** All private street entrances shall be paved within the highway right of way with 1.5 inches of bituminous mix 5E1 over 2.0 inches bituminous mix 3C (or a thickness as determined by the KCRC) over 8 inches of compacted aggregate (21-AA) over 12 inches sand sub-base (Class II) on local roads, or 18 inches of sand sub-base (Class II) on primary roads. If a concrete approach is approved, a minimum of 6 inches concrete (MDOT S-2 spec) with aforementioned sand sub-bases is required. Pavement is not required where a private street entrance is off an existing public gravel road. Where concrete curb is required, see Concrete Curb section under Commercial Driveways.
8. **Inspection:** The permittee shall provide all necessary staking and supervision of operations covered by the permit. The Kent County Road Commission's representative upon proper notice may check curb forms for concrete curb, but this shall not relieve the permittee of responsibility to insure conformance with the permit and applicable Road Commission standards. The permittee is responsible for the materials, performance, and actions of the contractor. Failure of the contractor to comply with the permit requirements may result in the suspension or cancellation of the permit.

### C. Traffic and Safety

1. All private street entrances shall be located where there is sufficient unrestricted sight distance to insure safety for the motoring public. The KCRC representative will assist the applicant or developer in making this determination, where the situation is in question.
2. The Engineering Department of the KCRC will approve all private street names. All property owners serviced by the private street must agree upon the street name. Street names chosen cannot be one currently used in Kent County (including Cities and Villages) or be similar sounding to any current public or private streets in Kent County. Addresses for any named private streets in the townships will be issued by the Permit Department of the KCRC, and will be of proper address sequence for the area and direction of the private street.
3. After all the entrance construction work has been completed to the satisfaction of the KCRC, the applicant may request that a private street name sign be installed where the private street intersects the public road. Cost of the sign and installation shall be paid in advance by the applicant. Signs made by the KCRC are limited to a total of seventeen (17) letters and spaces combined.
4. Parcels on the private street will be addressed from the private street, if such is named. If the private street is not named, addresses for parcels will be from the public road and be issued by the Permit Office of the KCRC.
5. Access of residential drive approaches on corner lots within a private development shall be off the private street, not the public street.

# KENT COUNTY ROAD COMMISSION

## STANDARD COMMERCIAL DRIVEWAY

### DETAIL "A"

PRIVATE STREET ENTRANCE (EXAMPLE) RURAL COUNTY ROAD WITH A.D.T. UNDER 1,000

FOR CULVERTS WHERE APPLICABLE, CORRUGATED METAL PIPE (MIN. 12" I.D.) OR SMOOTH LINED CORRUGATED PLASTIC PIPE (TYPE S - MIN. 12" I.D.) MAY BE USED. MUST MEET KCRC REQUIREMENTS.

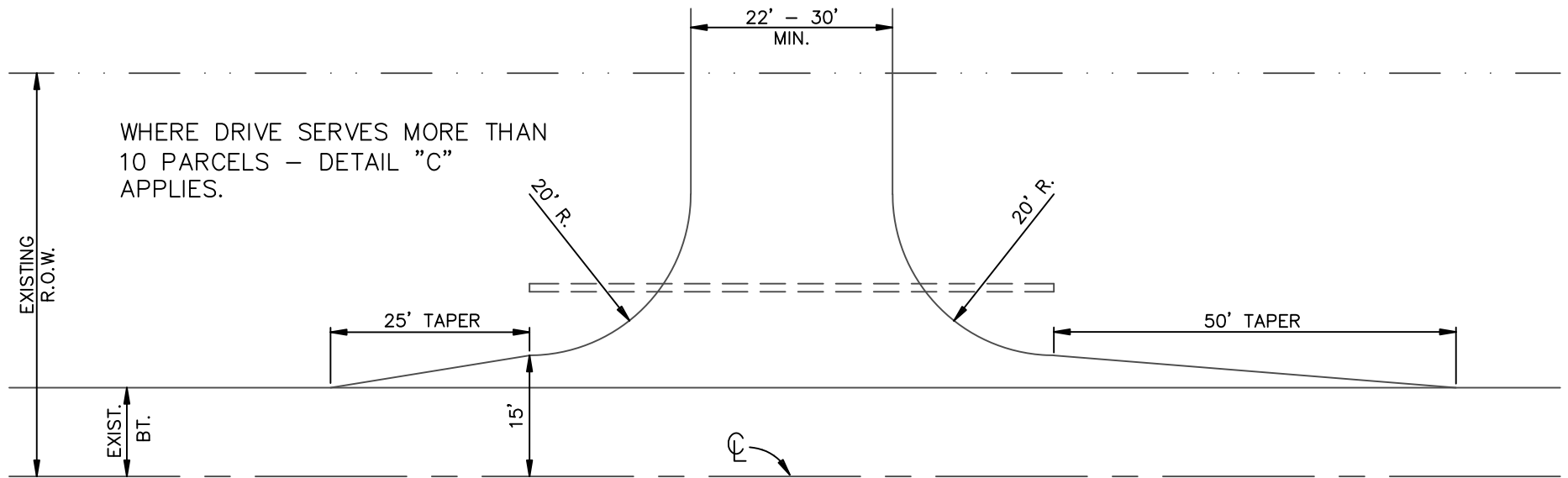

# KENT COUNTY ROAD COMMISSION

## STANDARD COMMERCIAL DRIVEWAY

### DETAIL "B"

PRIVATE STREET ENTRANCE (EXAMPLE) RURAL COUNTY ROAD WITH A.D.T. BETWEEN 1,000 – 2,000

WHERE DRIVE SERVES MORE THAN 10 PARCELS – DETAIL "C" APPLIES.

FOR CULVERTS WHERE APPLICABLE, CORRUGATED METAL PIPE (MIN. 12" I.D.) OR SMOOTH LINED CORRUGATED PLASTIC PIPE (TYPE S – MIN. 12" I.D.) MAY BE USED. MUST MEET KCRC REQUIREMENTS.

CURB AND GUTTER IS OPTIONAL

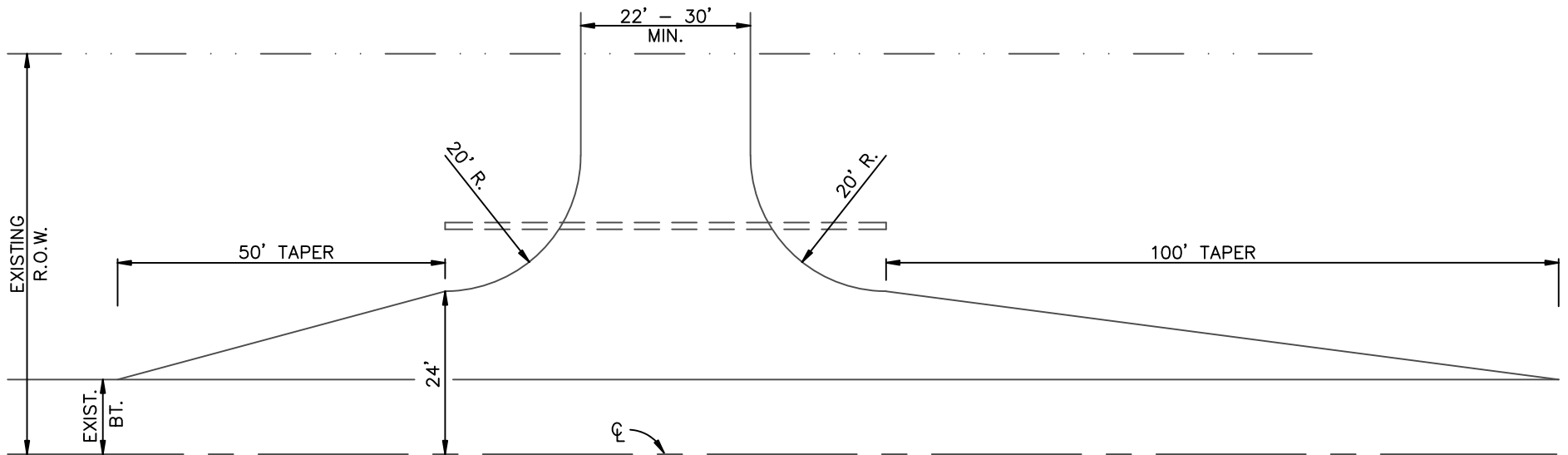

# KENT COUNTY ROAD COMMISSION

## STANDARD COMMERCIAL DRIVEWAY

### DETAIL "C"

PRIVATE STREET ENTRANCE (EXAMPLE) RURAL COUNTY ROAD  
WITH A.D.T. OVER 2,000 AND COMMERCIAL DRIVEWAY APPROACH

FOR CULVERTS WHERE APPLICABLE, CONCRETE PIPE  
IS REQUIRED ON ALL CURBED DRIVES. (CLASS A  
CONC. MIN. 12" I.D.)

CURB AND GUTTER IS REQUIRED

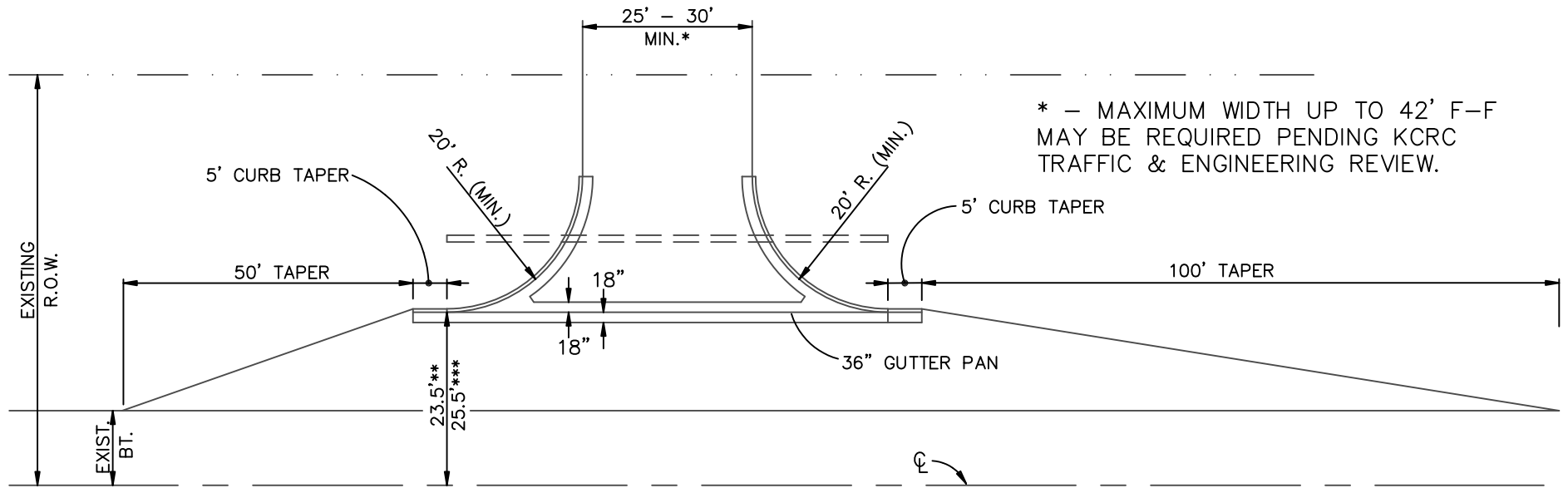

\* - MAXIMUM WIDTH UP TO 42' F-F  
MAY BE REQUIRED PENDING KCRC  
TRAFFIC & ENGINEERING REVIEW.

\*\* LOCAL ROAD STANDARD OFFSET  
\*\*\* PRIMARY ROAD STANDARD OFFSET

## SECTION 4

### RESIDENTIAL DRIVEWAYS

#### A. Definition

For purposes of these rules, a residential driveway is any driveway serving a single residential or two family dwelling (duplex).

#### B. Geometric and Construction Standards

- 1. Width:** All residential driveways shall have a minimum width of 10 feet and a maximum width of 24 feet (32 feet may be allowed for a 3 stall garage), measured at right angles to the centerline of the driveway at the public right-of-way line.
- 2. Flares:** To facilitate vehicle movements, each side of the driveway approach shall be offset with 4 foot flares, measured at the pavement edge not to exceed 32 feet unless otherwise approved by the Kent County Road Commission (KCRC).
- 3. Location:** Driveways shall be located so that no undue interference with the free movement of public highway traffic will result, and to provide the best vision and grade conditions. A 10 foot separation from the edge of driveway to property lines and public utilities (i.e. power/phone poles, fire hydrants, cable/phone boxes, etc.) is preferred unless sight distance warrants less. No portion of a residential driveway shall be located closer than 50 feet from the edge of the driveway to the nearest public right-of-way line or vision corner of an intersecting public road. No portion of two residential driveways serving the same property shall be located closer than 40 feet to each other measured edge to edge. All measurements are along the public right-of-way line. Unless written permission is obtained from adjacent property owners, no portion of a residential driveway shall extend beyond the adjacent property lines extended to the edge of the road.
- 4. Number of Driveways:** One residential driveway will be permitted for each platted lot or for the first 100 feet or less of residential property in unplatted areas. Circle drives may be permitted if the frontage exceeds 100 feet.
- 5. Profile:** Unless otherwise determined by the KCRC, all residential driveways shall be built to a sidewalk elevation at the right-of-way line in accordance with the Kent County Road Commission's Table for Determining Sidewalk Grades. It is recommended beyond the right-of-way line the grade should not exceed 8 percent, or meet local government agency requirements.
- 6. Drainage:** If deemed necessary by the KCRC, site drainage plans must be provided. The residential driveway shall be so constructed that the drainage to or along the public roadway is not at a greater rate than what historically drained from the lot/land area. In special drainage instances, other alternative drainage systems will be reviewed by the KCRC. When required, culverts of a size determined by the KCRC will be placed in accordance with the Kent County Road Commission's Driveway Culvert Policy. Any future culvert replacement and driveway surface replacement (bituminous/concrete) is done at cost of property/home owner.

7. **Surface:** On a gravel public roadway, all residential driveways shall be surfaced within the public right-of-way with a minimum of 8" gravel. On a paved public roadway drive approaches may be surfaced with either bituminous or concrete. Bituminous must be a minimum of 3.5" bituminous mixture over a minimum of 6" compacted aggregate (21-AA) over 12" Class II sand subbase on local roads, or 18 inches of Class II sand subbase on primary roads. A concrete approach must be a minimum of 6" concrete (MDOT S-2 spec.) over 12" of Class II sand subbase (local roads) or over 18" of Class II sand subbase (primary roads). Concrete approaches in plats or on public roads with a 2 foot bituminous valley gutter along the driveway location frontage may meet up to the back of the bituminous valley gutter. Concrete approaches in non-valley gutter areas must have at least a 4 foot wide hot mix asphalt shoulder beyond the existing edge of pavement before a concrete approach can begin (see example below).
8. **Construction Staking:** Stakes for location and elevation necessary for construction may be placed by the KCRC upon request, after issuance of the residential driveway permit.

### C. Joint Driveways

1. A joint residential drive for a duplex must have a written/recorded easement agreement verified to the KCRC and local government agency.

#### STANDARD RESIDENTIAL CONCRETE DRIVEWAY DETAIL

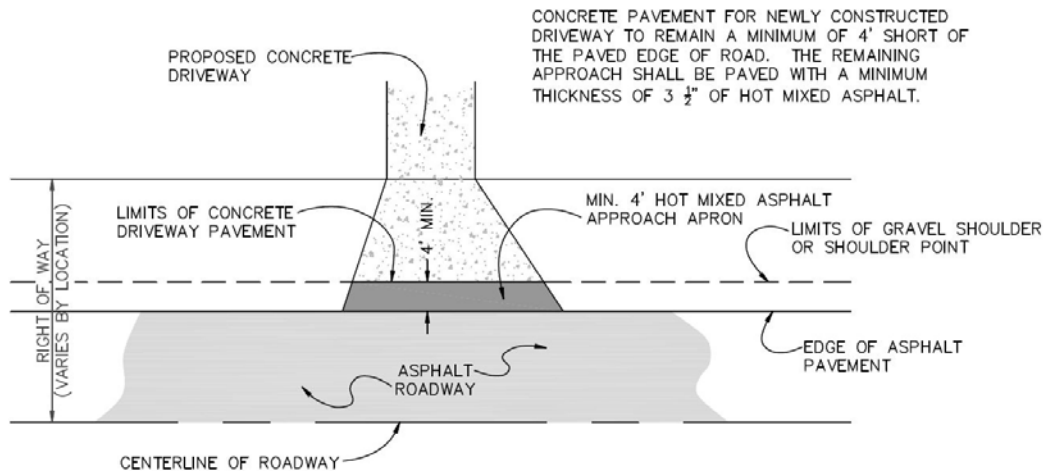

## SECTION 5

### FIELD ENTRANCE DRIVEWAYS

#### A. Definition

For purposes of these rules, any driveway serving cultivated fields (agricultural), timberland, or undeveloped land not used for industrial, commercial, or residential purposes shall be considered field entrance driveways.

#### B. Standards

1. The requirements for field entrance driveways shall be the same as residential driveways, except the surface shall be a minimum of 8" of gravel, sodded, or better type of material. Also, for agricultural purposes, the width of a field entrance may be enlarged to a 32 foot maximum to accommodate large farm machinery. Smallest culvert size allowed is a 12" dia. culvert, 32 foot long. Maximum length allowed is 48 feet for a 3 foot ditch depth, or 54 feet for a 4 foot ditch depth.



## SECTION 6

### BANNERS

#### A. Definition

For purposes of these rules, a banner is an arrangement of lettering, words, symbols or a decorative device, including a Christmas decoration, suspended over any portion of a public highway or within the highway right of way.

#### B. Permittees

A permit for the installation of banners to be placed within a public highway right of way may be issued by the Kent County Road Commission (KCRC) only to the governing agency of a city, village or township.

#### C. Design and Placement

1. The design, method of installation and location of banners shall not endanger persons using the public highway, public highway right of way, or unduly interfere with the free movement of traffic.
2. An overhead banner shall have a minimum bottom height of 18 feet above any pavement or ground, shall not be placed closer than 10 feet to any side of traffic signals or regulatory signs, and shall not be placed so as to obstruct a clear view of traffic signals or other traffic control devices. Banners shall not be mounted from or attached to any public agency regulatory traffic signs or signals.

#### D. Content of Banners

1. A banner shall not display any legend or symbol which may be construed to advertise, promote the sale of or publicize any merchandise or commodity, or to be political in nature.
2. A banner shall not display any legend or symbol which is or purports to be an imitation of or resembles, or which may be mistaken for, a traffic control device, or which attempts to direct the movement of traffic.
3. Decorations shall not include flashing lights that may be distracting to motorists.

#### E. Duties of Local Governments

1. A city, village, or township receiving a permit shall faithfully fulfill permit requirements and shall indemnify and save harmless the KCRC from claims of every kind arising out of the use of an issued permit.

## **F. Application**

1. To obtain a permit for the installation of a banner, the appropriate form available at the Permit Office of the KCRC must be filled out and signed by the local governing agency involved (city, village, township).
2. An application shall include the following information:
  - a. Activity in connection with which the banners are to be placed.
  - b. Location of the proposed installation including distance to overhead traffic control devices.
  - c. Description of the banners, including language content, any legend or symbol thereon.
  - d. Height of an overhead banner at its lowest point above the pavement or ground.
  - e. Date on which the banner will be installed and removed. This period shall not exceed a time period specified by the KCRC. An acceptable period of time for banners, other than Christmas decorations, to be in place is three (3) weeks, and an acceptable duration for Christmas decorations to be in place is six (6) weeks.
  - f. Such other information as the KCRC may require.

## **G. Resolutions**

1. An application shall be accompanied by a copy of a resolution from the local governing agency designating an authorized official of the city, village, or township who has authority to make applications.

## **H. Cancellation**

1. A permit for the installation of a banner may be canceled by the KCRC if the installation is determined by the KCRC to be dangerous to motorists or unduly interferes with the free movement of traffic.

## SECTION 7

### PARADES – CELEBRATIONS – FESTIVALS

#### A. Permittees

A permit granting permission for the temporary full closure, partial road closure, lane closure, or a change in traffic control of a public highway for a reasonable length of time for a parade, celebration, festival, block party, road run, bike races/ride, or other event may be issued by the Kent County Road Commission (KCRC) only to the governing agency of a city, village, or township.

#### B. Application

1. To obtain a permit to close or partially close, or change traffic control of a public highway for a parade, celebration, festival, or other event, the appropriate form available at the Permit Office of the KCRC must be filled out and signed by the local governing agency involved (city, village, township).
2. An application shall state the nature of the activity for which the permit is requested, the dates and times it is proposed to close and reopen the public highway to full traffic, the events lead/head contact person's name, address, and phone number, and such other information as the KCRC may require. The application must be accompanied by a copy of a resolution or board action of the city, village, or township approving the event or approval by an authorized official designated by resolution of the governing body of a city, village, or township.
3. The application should be submitted at least 30 days prior to the event.

#### C. Permit Conditions

1. The closure or partial closure and the use of a detour route shall not unduly interfere with the safe and free movement of traffic.
2. The KCRC may require an alternate location for the parade, celebration, festival, or other event which is more acceptable for traffic safety, and causes less interruption of traffic.
3. A closure or partial closure normally shall be allowed during daylight hours only. If a temporary night time closure is permitted, points of potential hazard, barricades and traffic signs shall be lighted at the permittee's expense. The lighting shall be in accordance with requirements and specifications of the KCRC.
4. The KCRC shall determine the acceptable detour routes. All traffic control devices installed in conjunction with the closure or partial closure and the detour route shall conform to the provisions of the current Manual of Uniform Traffic Control Devices.
5. Required traffic control devices shall be furnished, installed, and maintained by the local governing body the permit is issued to, and will not be provided by the KCRC.

6. The local governing agency shall provide necessary police supervision, and assume liability for damage claims, which may arise as a result of the closure or partial closure.
7. The closure or partial closure shall not be for the purpose of allowing private commercial activities, such as advertising or sale of goods, wares or produce.
8. A Certificate of Insurance naming the KCRC as additional insured may be required.

## SECTION 8

### CONDITIONS OF ISSUANCE OF DRIVEWAY PERMITS

#### A. Conditions

All driveway permits issued in accordance with these rules shall be subject to the following conditions:

1. The property owner or lessee shall maintain all driveways set forth in the permit.
2. The Kent County Road Commission (KCRC) shall be notified at least 48 hours (excluding weekends and holidays) prior to commencement of any operation covered by the permit.
3. The owner, or his authorized agent, shall provide and maintain all necessary precautions to prevent injury or damage to persons and property from operations covered by the permit and shall use warning devices in accordance with the Michigan Manual of Uniform Traffic Control Devices.
4. All unsuitable or surplus materials shall be removed and disposed of outside of the highway right-of-way unless otherwise authorized. Excavated material and materials or equipment necessary for construction of the driveway shall be so located that the safety of traffic will not be interfered with.
5. Certificate of insurance to insure that claims for damage or personal injury can be met shall be provided in the amount currently specified by the KCRC. Surety Bond to protect the KCRC against the cost of completing construction or correcting deficiencies shall be provided on forms obtainable from the KCRC.
6. Driveway construction must be completed within one year from date of permit issuance. Failure to comply can result in the KCRC completing the necessary construction by exercising the Surety or at owner's expense.
7. KCRC reserves the right to terminate or revoke any permit if any terms, construction, or safety requirements as deemed necessary by the Road Commission or as shown on the approved permit plan are not met or resolved in a timely manner.
8. When additional grading or cutting is required in the highway right of way, work must be preapproved by the KCRC.

## SECTION 9

### PERMIT PROCEDURE

The following procedure is required to obtain a permit for a driveway, banner, or parade within the highway right-of-way under the jurisdiction of the Board of County Road Commissioners of the County of Kent:

**A. Procedure:**

1. The property owner or governmental agency will make an application on the appropriate form available at the Permit Offices of the Kent County Road Commission (KCRC). The application shall be accompanied by a scaled plan containing information that clearly indicates all existing and proposed items in accordance with these rules.
2. The Permit Department of the KCRC shall determine compliance of the application request to these rules and will advise on any revisions that may be necessary in order to comply.
3. The appropriate permit fees and performance bonds if applicable are submitted.
4. After review and approval, the permit is mailed or given to the property owner or governmental agency. Any details pertaining to specific requirements will be outlined on the permit and/or plan.
5. Necessary construction staking for sidewalk grades on residential driveways will be done within a reasonable time after a request is made to the KCRC.
6. Materials, equipment, and warning devices necessary to do the work shall be obtained by the permittee, and the Engineering Department of the KCRC will be notified 48 hours (excluding weekends and holidays) before start of work.
7. All work or operations shall be completed in accordance with all rules and supplemental conditions as outlined on the permit/approved plan. Work done without prior notification or inspection by the KCRC, which does not meet specifications and standards, may be required to be removed and replaced at the permittees expense.